

Caja estanca con conos



La gama de cajas estancas JSL esta fabricada en 3 líneas diferentes conforme las exigencias reglamentarias de instalación, en lo que respecta al ensayo sobre el hilo incandescente:

M2 850° C Cajas de derivación o envolventes para cuadros para instalación en paredes huecas o locales recibiendo el público.

M0 960° C Cajas de derivación para instalación de circuitos de seguridad o locales recibiendo trabajadores.

EXT			INT			G	H	I	J	K
A	B	C	D	E	F					
85	-	51	80	-	45	7	44	-	-	57
88	88	51	80	80	50	10	41	60	60	-
110	100	65	100	100	55	18	46	89	89	-
160	120	78	150	110	70	22	56	105	83	-
185	121	77	175	110	65	22	55	162	99	-
185	121	94	175	110	83	38	55	162	99	-
200	160	81	190	150	70	18	63	177	138	-
200	160	102	190	150	92	38	63	177	138	-
230	180	108	220	170	105	20	86	206	158	-
230	180	130	220	170	120	42	86	206	158	-
345	304	187	330	280	175	22	165	267	170	-
440	410	187	430	390	175	22	165	267	170	-

Caja estanca con conos

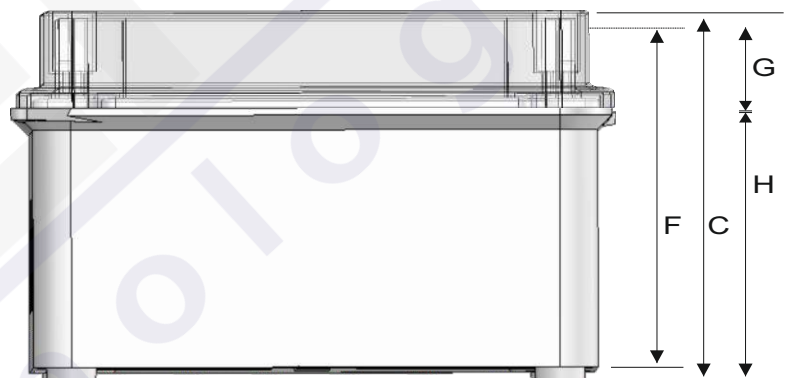
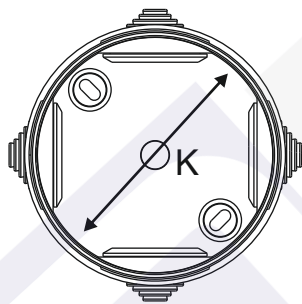
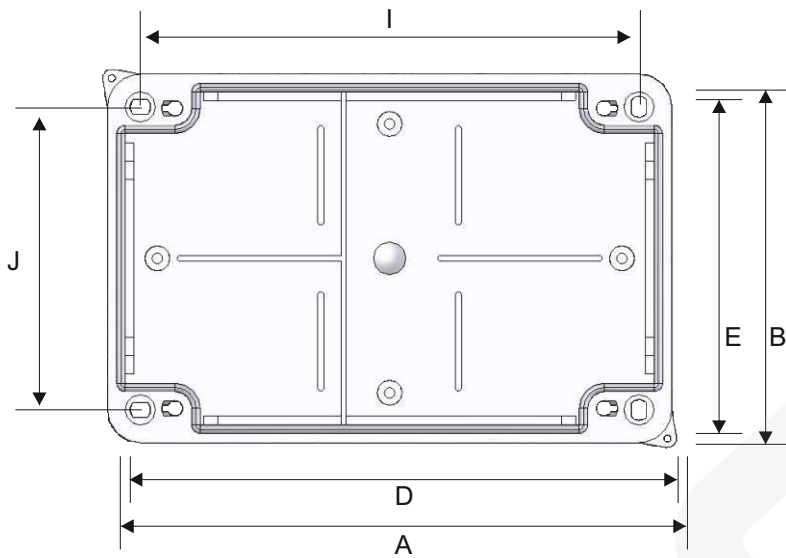

Ideal Technology has a policy of continuous improvement. Specifications are subject to change without notice.