

DATASHEET

100 Pair 110 Patch Panel

PA11001

Package includes:

- A. 110 Blank Patch Panel, 1 pc
- B. 50-Pair 110 Block, 2 pcs
- C. Designation Label, 2 pcs
- D. Label Holder, 2 pcs

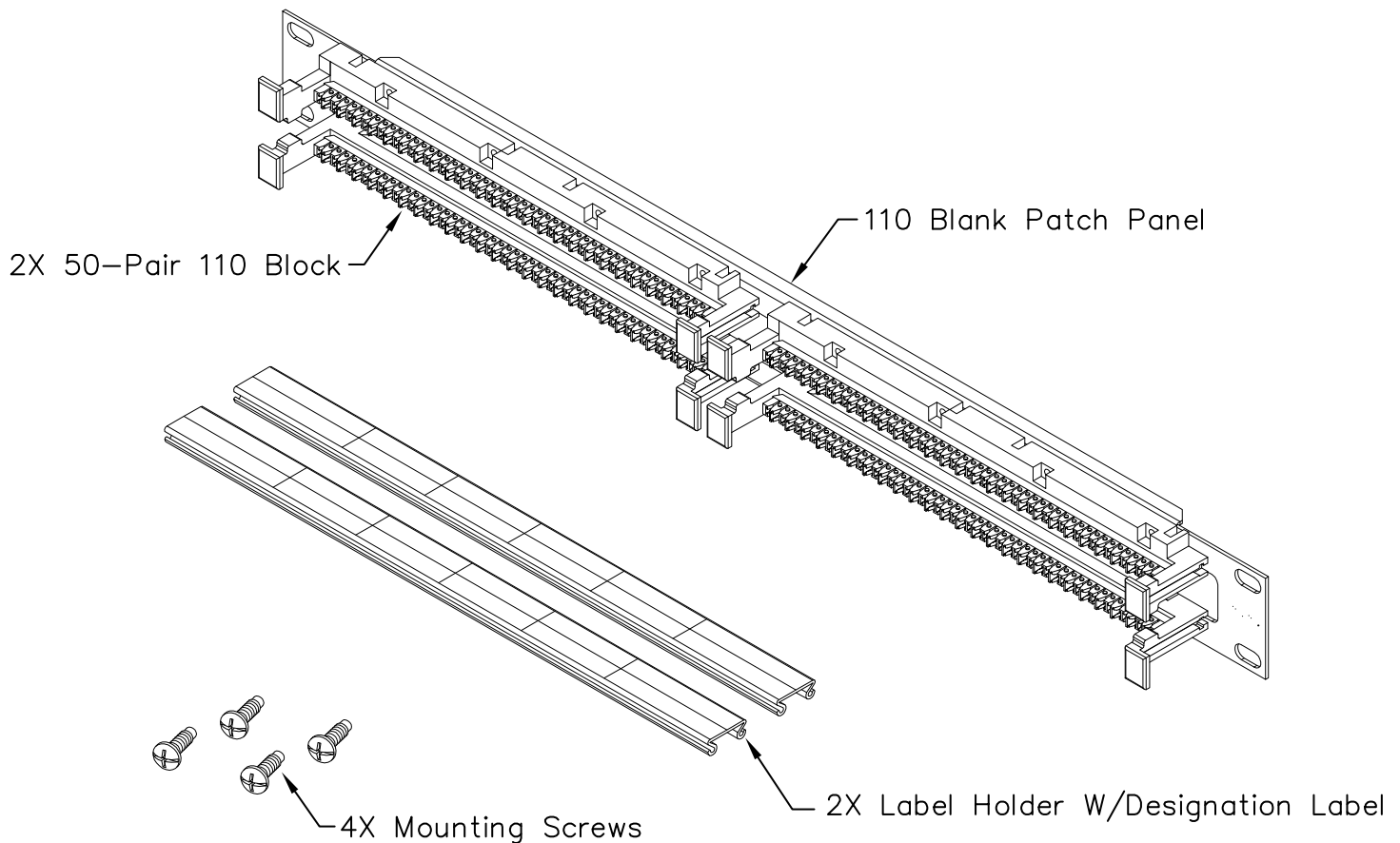

Features and Benefits:

- Rack mounted reinforced steel panel with two 50-pair 110 blocks
- Designed to support the distribution of voice and data needs for commercial or residential applications
- Designed with rear cable entry for flexibility
- Designed to fit all standard 19" racks and cabinets
- Label designation and holder for easy identification
- 1 rack mount space (RMS)
- ANSI/TIA-568-C and UL 1863 compliant