

200 Pair 110 Patch Panel

Package Includes:

- A. 110 Blank Patch Panel, 1 PC
- B. 50-Pair 110 Block, 4 PCS
- C. Designation Label, 4 PCS
- D. Label Holder, 4 PCS
- E. #12-24 x 5/8" Pan Head, Pilot Point Machine Screw, 4 PCS

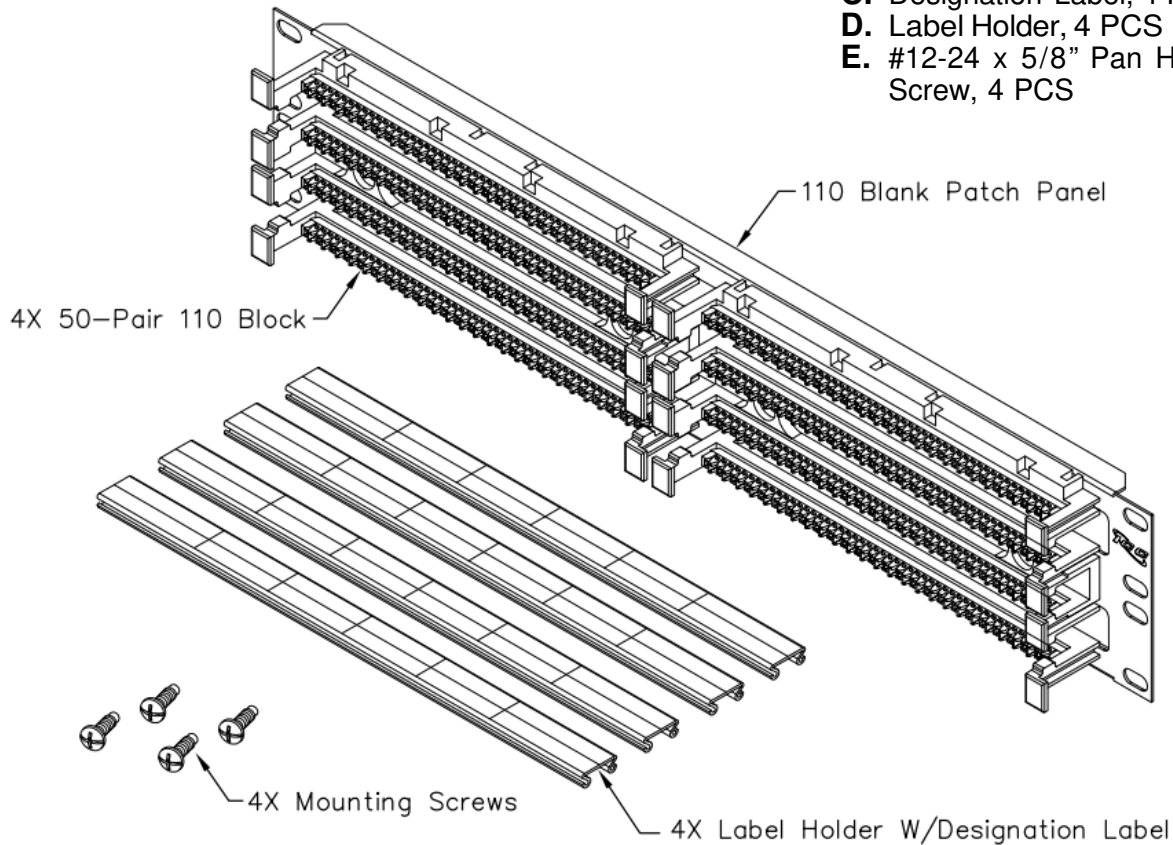

Features and Benefits

- Rack mounted reinforced steel panel with four 50-pair 110 blocks
- Designed to support the distribution of voice and data needs for commercial or residential applications
- Designed with rear cable entry for flexibility
- Designed to fit all standard 19" racks and cabinets
- Label designation and holder for easy identification
- 2 rack mount space (RMS)
- Used with IC110CB 110 connecting blocks, ICACSPDT00 and ICACSPDT05 110 punch down tools
- ANSI/TIA-568-C and UL 1863 compliant
- Country Of Origin: Taiwan
- TAA Compliant

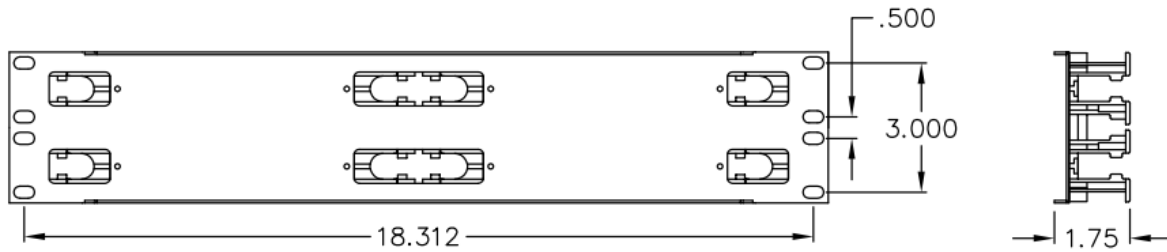
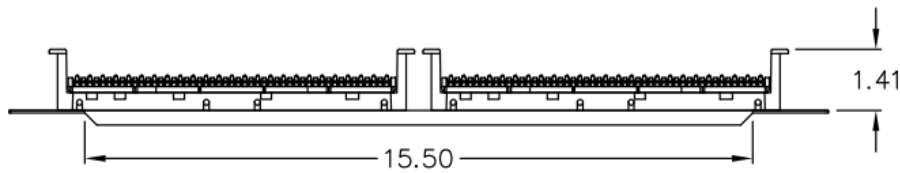
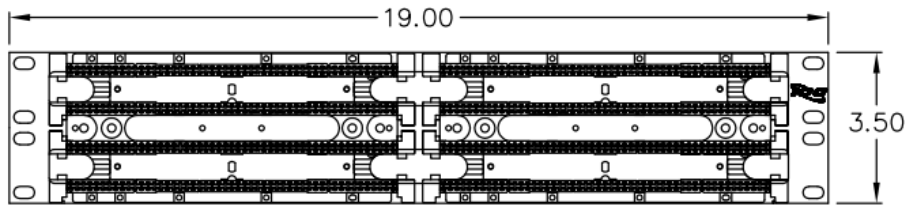

NOTE: UNLESS OTHERWISE SPECIFIED

1. 110 BLANK PATCH PANEL
 - A. MATERIAL: 16 GA CRS
 - B. SURFACE FINISHING: BLACK POWDER COAT
2. 50-PAIR 110 BLOCK:
 - A. MATERIAL: PC, UL 94V-0
 - B. COLOR: IVORY
3. PERFORMANCE:
 - A. PERFORMANCE EXCEEDS CATEGORY
HARDWARE REQUIREMENTS SPECIFIED IN TIA/EIA-566-B.2